

# 100W LED HIGH BAY LIGHT



## AREAS OF APPLICATION

Heavy & light Industry Production  
Assembly Line  
Warehouse & Storage Facilities  
Commercial Assembly Halls  
Loading Areas  
Mall & Supermarket Lighting  
Aircraft Hangers

## PRODUCT SPECIFICATION :

**Housing** : High grade Aluminium pressure Die-Cast

**Lamp Efficacy** : >100 lumen/Watt

**System Management** : Multiple LEDs are used in series - parallel cluster

**Control Gear** : CC-CV Control driver with efficiency >90%, current regulator for each cluster

**Protection Degree** : IP65/IP66

**Thermal Management** : Effective Heat Sinking, Ensure long life

**Surge Protection** : Upto 10KV

**CRI** : Superior color rendition index compared to HPSV, MH, Traditional lights

**Special Feature** : Over voltage protection , Reverse EMI protection provided , Short circuit protection , Open circuit protection

**BIS** : BIS approved driver IS 15885 (Part 2/Sec13) :2012 , R-84000787

## Technical Details :

Model No.	Rated Wattage	Nominal Voltage	Color	CRI	PF	THD	Lumen O/P
MLAC-HB100P	100W	140V-285V	CW/WW	>80	>0.95	<10%	10000 lm

## Dimensions :

Wattage	Diameter	Height
100W	380mm	140mm

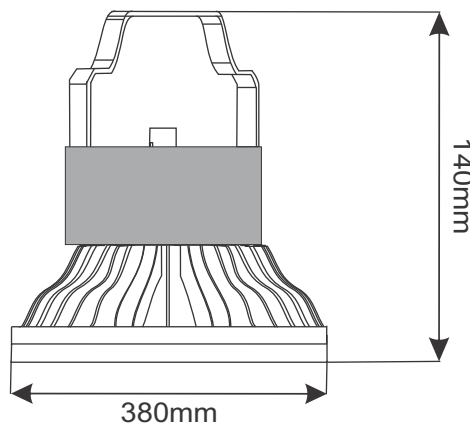

## Saving at a Glance :

### LED vs. HID savings at a glance

Why are so many facilities making the switch from HID to LED?

The numbers say it all.

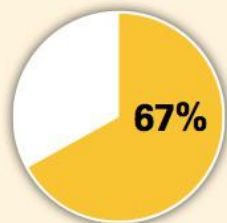

67% REDUCTION IN ENERGY COSTS

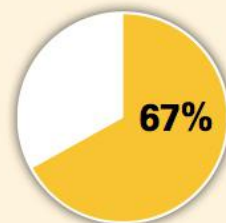

67% LOWER TOTAL COST OF OWNERSHIP



100% MAINTENANCE REDUCTION